

Parallel mode



Table of contents

1	PARALLEL MODE	3
1.1	Requirements 5-10H	4
1.2	Requirements 12-50H	4
1.3	Software	4
1.4	Parallel Inverter Connection	4
1.5	Connecting the inverter via Bluetooth	5
1.6	Parallel settings Master	6
1.7	Parallel settings Slave	6
1.8	Set „Parallel Sync“	6
2	DISCLAIMER OF LIABILITY	7

1 Parallel mode

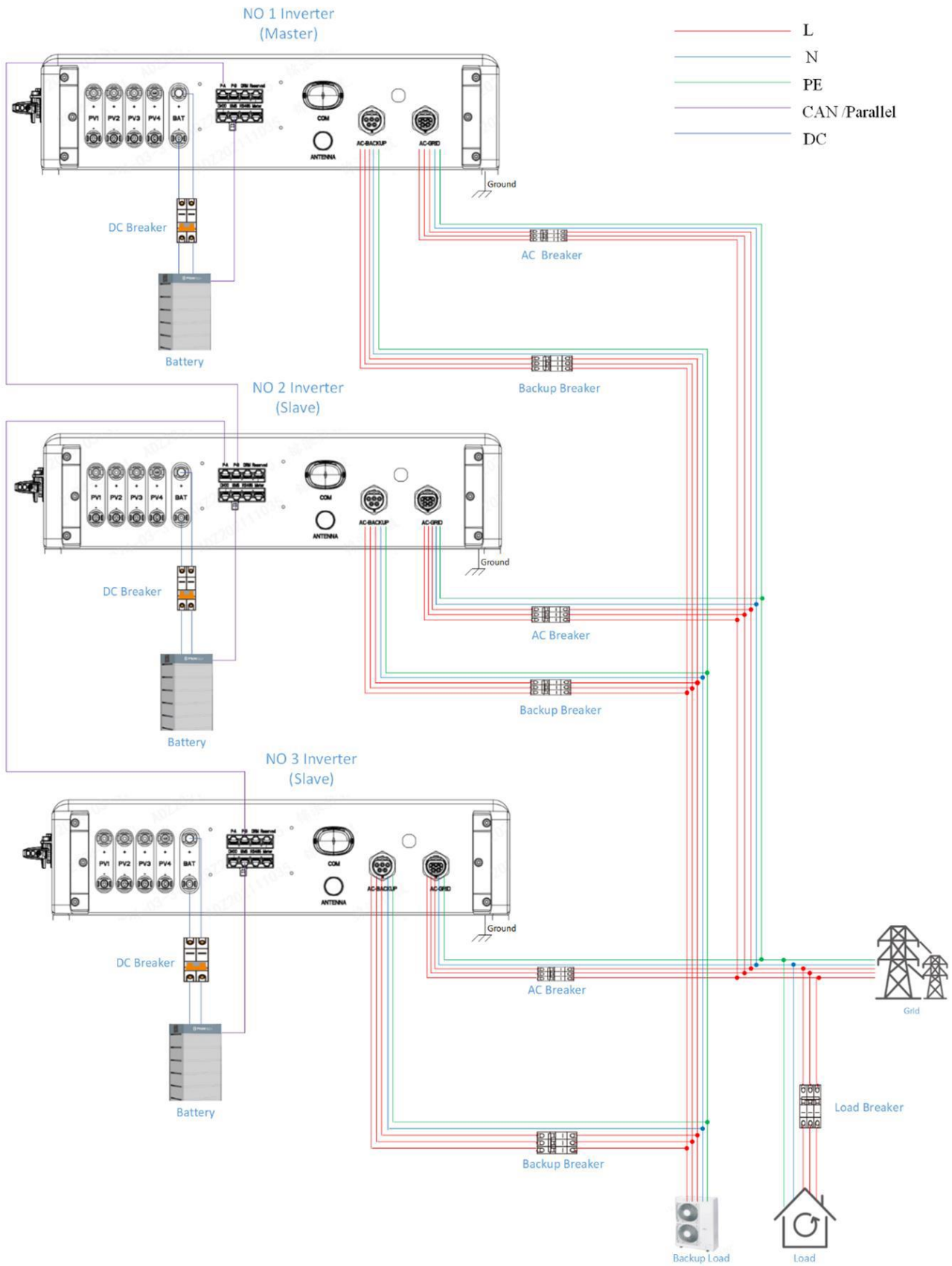

1.1 Requirements 5-10H

Up to three units of the inverter can be connected in parallel. The parallel-connected systems must be technically identical.

Examples:

Not compatible: AXIhycon 5H with AXIstorage Li SV2 6.7 kW + AXIhycon 5H with AXIstorage Li SV2 10.1 kW

Not compatible: AXIhycon 5H with AXIstorage Li SV2 6.7 kW + AXIhycon 8H with AXIstorage Li SV2 6.7 kW

Compatible: AXIhycon 5H with AXIstorage Li SV2 6.7 kW + AXIhycon 5H with AXIstorage Li SV2 6.7 kW

Only identical systems can be operated successfully in parallel.

1.2 Requirements 12-50H

Up to six units of the inverter can be connected in parallel. The parallel-connected systems must have the same inverter type but can vary in the battery configuration.

1.3 Software

A software update may be required for parallel operation of the inverters. Please connect the inverters to the Internet and send us the serial numbers. You can reach us by phone or email:

E-Mail: service@axitecsolar.com

Phne: +49 7031 - 62 88 51 73

We also ask you to ensure that the connected power storage units have the latest software version installed.

1.4 Parallel Inverter Connection



The inverter's parallel communication terminals P-B and P-A should be connected in a daisy chain configuration.

E.g. Inverter Master P-B >> Slave 1 P-A || Slave 1 P-B >> Slave 2 P-A

The communication cables are supplied with the inverter. Normal straight Ethernet cables with RJ45 connectors can also be used for the parallel connection between the inverters.

The toggle switches on the master and the last slave inverter must be set to "ON". The slave inverters in between keep the toggle switches set to "Off".

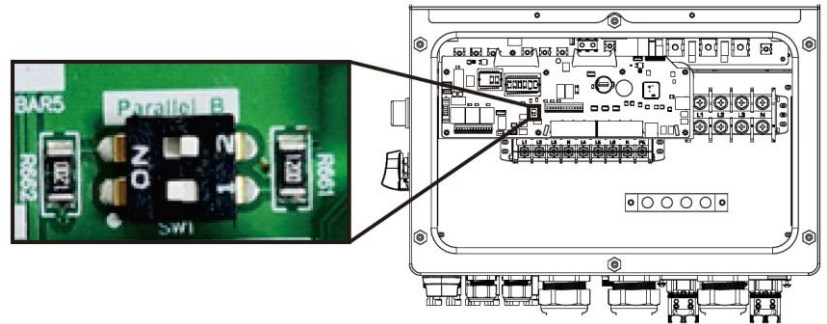
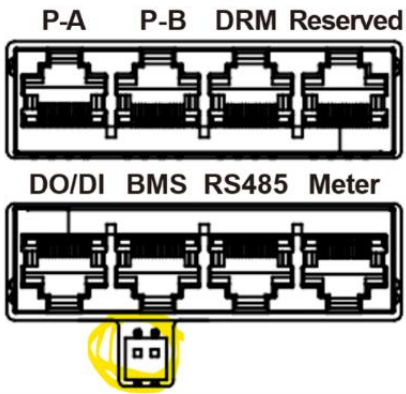

1.5 Connecting the inverter via Bluetooth

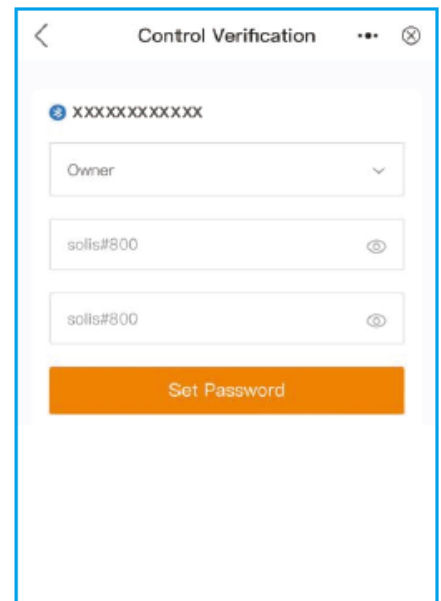
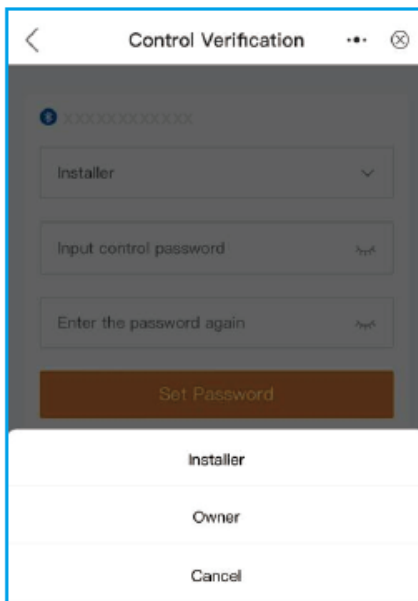
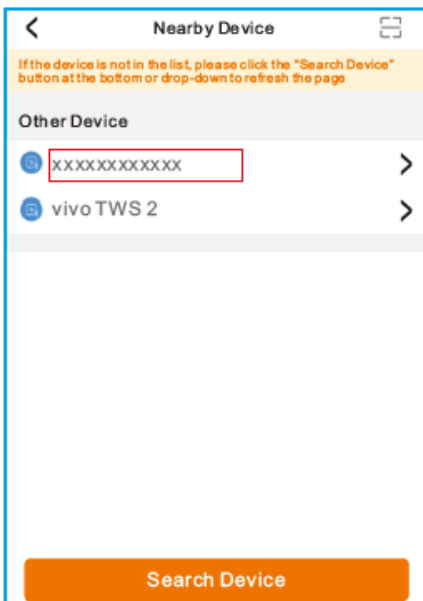
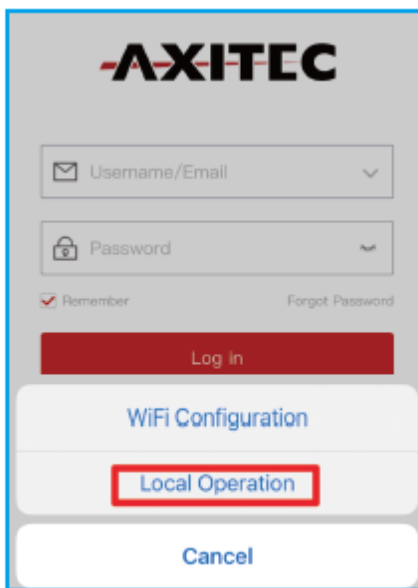
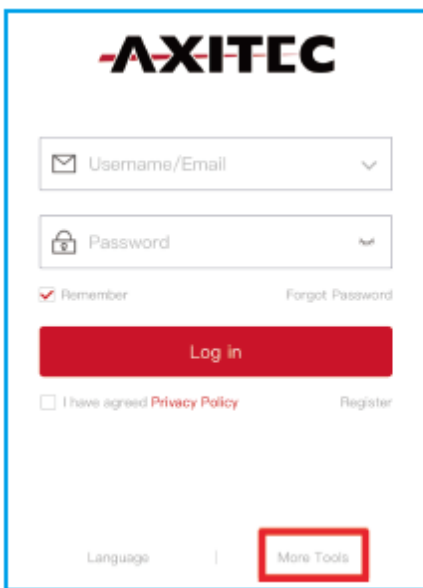

1.6 Parallel settings Master

Parallel Mode -> Parallel

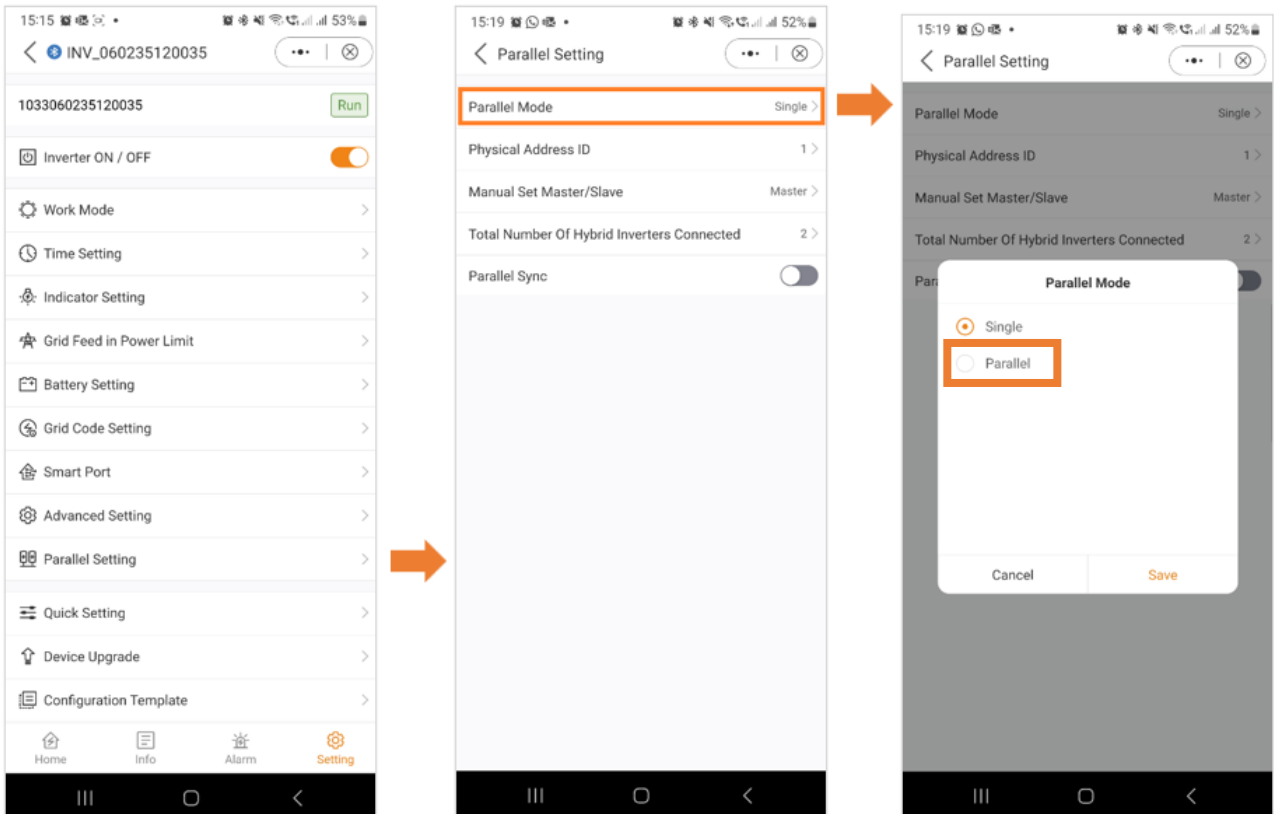

1.7 Parallel settings Slave

Parallel Mode -> Parallel

Physical Address ID -> ("2" for 1st Slave or "3" für 2nd Slave, etc.)

Manual Set Master/Slave -> Slave

Total Number Of Hybrid Inverters Connected -> (2 to 6)

Parallel Sync -> off

1.8 Set „Parallel Sync“

When Parallel Sync is enabled, the system ensures that the power of all connected inverters is evenly synchronized. This feature helps maintain a balanced power distribution across multiple inverters, contributing to the overall stability and efficiency of the system. Before selecting parallel synchronization, make sure you select all your settings first and then this last.

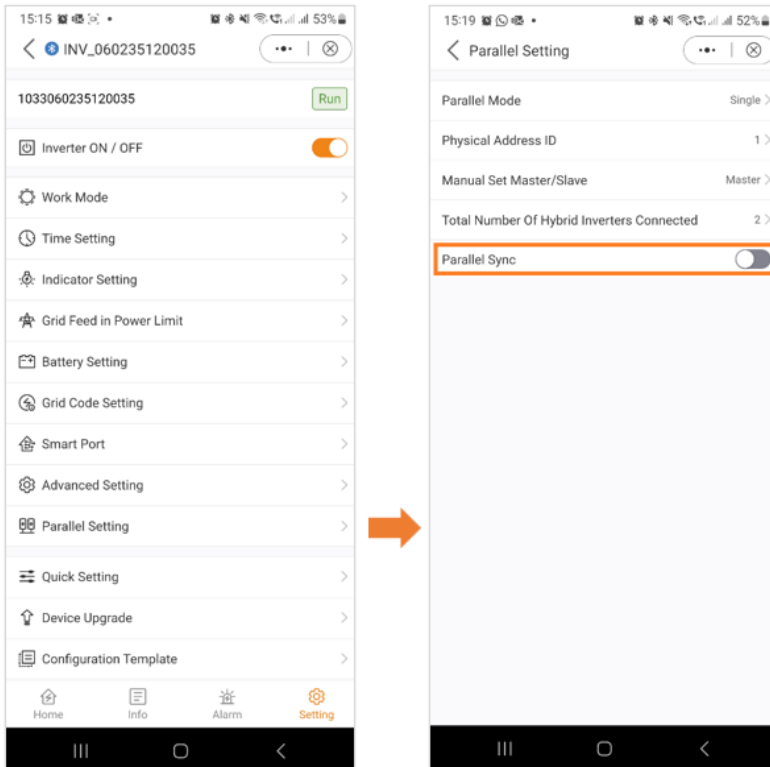

2 Disclaimer of liability

As compliance with this user information as well as the conditions and methods of installation, operation, use and maintenance of the hybrid inverters cannot be controlled or monitored by AXITEC Energy GmbH & Co. KG, AXITEC Energy GmbH & Co. KG assumes no liability for damage resulting from improper use, incorrect installation, operation, use or maintenance.

In addition, liability for patent infringements or infringements of other third-party rights resulting from the use of the hybrid inverters is excluded, unless liability is mandatory by law.